

# FR LOW ΔP HIGH PROOF PRESSURE DIFFERENCE SWITCHES

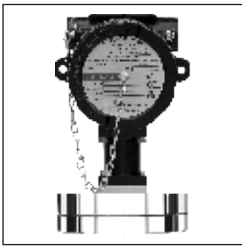

## PRESSURE CAPSULE DETAILS

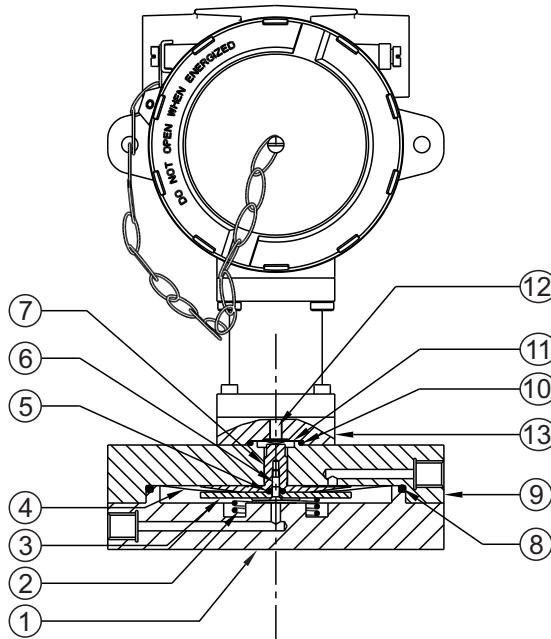

### No. Description

1. High Pressure Housing
2. Spring
3. H P Plunger
4. Diaphragm
5. Plunger 'O' ring
6. Plunger Screw
7. L P Plunger
8. Main Sealing 'O' ring
9. Low Pressure Housing
10. Sealing 'O' ring
11. Diaphragm
12. Small Plunger

Note : *wetted parts* are mentioned in italics.

## INSTALLATION DRAWING

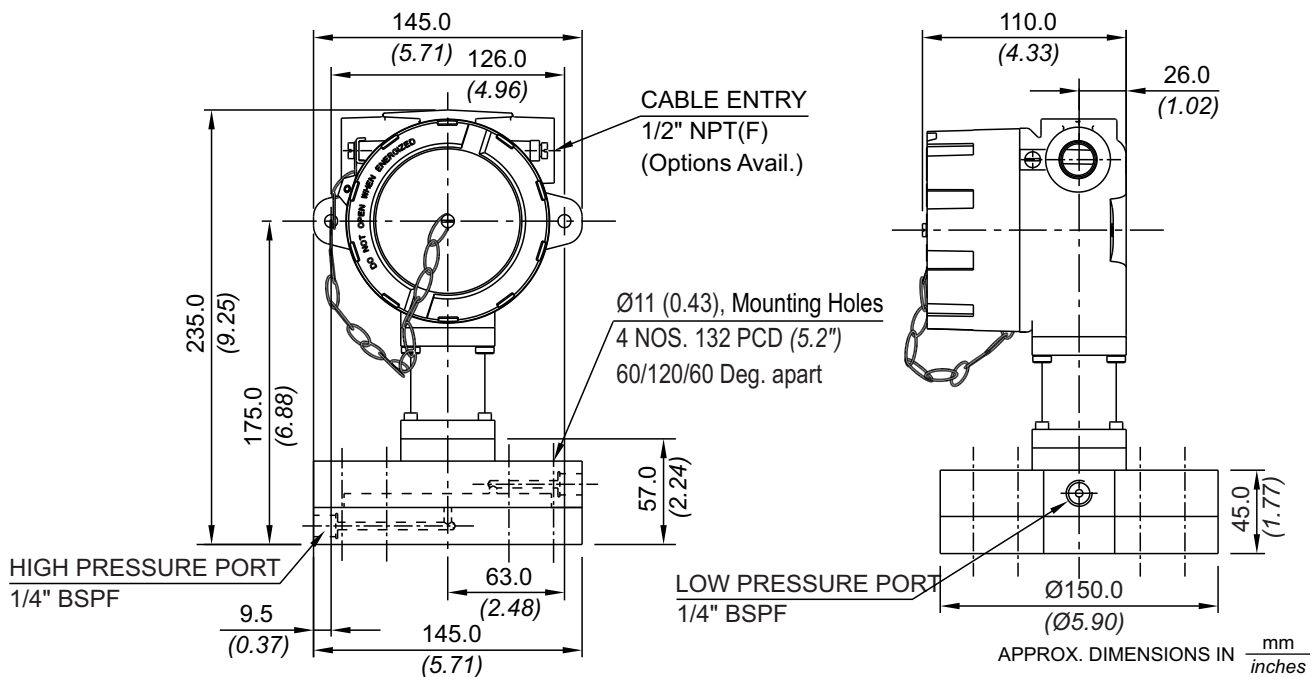

## RANGE SELECTION TABLE

Range Code	Range mbar ("wc)	Differential* mbar ("wc)	Maximum Working Pressure bar (psi)
		Approximate Maximum for "A1" microswitch	
M03	5 to 25 (2.007 to 10.046)	5.0 (2.009)	100.0 (1450.38)
M05	10 to 50 (4.018 to 20.093)	5.0 (2.009)	100.0 (1450.38)
M10	10 to 100 (4.018 to 40.186)	10.0 (4.018)	100.0 (1450.38)
M15	10 to 150 (4.018 to 60.280)	10.0 (4.018)	100.0 (1450.38)
M25	20 to 250 (8.037 to 100.466)	15.0 (6.028)	100.0 (1450.38)
M35	50 to 350 (20.093 to 140.653)	35.0 (14.065)	100.0 (1450.38)

## Note:

1. The minimum differential increases with the setpoint. The differential values mentioned in the above table are approximate maximum for FSR. The differential value will vary according to the pressure range selected and microswitch type. For actual values of differential please contact sales office.

2. When using 2SPDT switching arrangement, both microswitches may not actuate and/or deactuate at the same point. A small stage gap, normally upto +/- 5% FSR (depending on range code) may be observed. The On-Off differential (hysteresis) typically tends to be atleast double of those published for 1SPDT pressure switches.

If actuation and/or deactuation at same point is critical part of operation, then it can be achieved by using a separate DPDT relay. This relay will need a separate power supply for it's coil.

**Intrinsic Safety (Exia)** : Pressure and temperature switches are classified as simple apparatus, as per IEC 60079-11, as they neither store or generate energy. Hence switches can be used in intrinsically safe systems provided the power source is IS certified. Because of low voltages and current it is recommended to use hermetically sealed microswitches / microswitches.

# HOW TO ORDER FLAMEPROOF LOW ΔP HIGH PROOF RANGE PRESSURE DIFFERENCE SWITCHES

## LOW ΔP HIGH PROOF PRESSURE DIFFERENCE SWITCHES



Group 1	Group 2	Group 3	Group 4	Group 5	Group 6	Group 7	Group 8								
<p>Non standard allocation</p> <p>□ A prefix "N" is used in the model code in case of any non standard options / accessories that are provided with the switches. Will be given by manufacturer, only after agreement of supply details with customer.</p> <p>The prefix is subject to change as per specific requirement.</p> <p>Approx. switch weight in Kgs</p> <table border="1"> <tr> <td><b>Enclosure</b></td> <td><b>FR</b></td> </tr> <tr> <td>Aluminium</td> <td>7.870</td> </tr> <tr> <td>Grey CI</td> <td>10.270</td> </tr> <tr> <td>SS</td> <td>10.420</td> </tr> </table>	<b>Enclosure</b>	<b>FR</b>	Aluminium	7.870	Grey CI	10.270	SS	10.420	<p>Model</p> <p><b>FR</b> = IP66 Flameproof pressure switch, EAC approved</p>	<p>Cable Entry Size</p> <p><b>1</b> = Al. head 1/2" NPT threads  <b>2</b> = Al. head 3/4" NPT threads  <b>3</b> = Al. head M20 x 1.5 threads  <b>*4</b> = Grey CI head 1/2" NPT threads  <b>*5</b> = Grey CI head 3/4" NPT threads  <b>*6</b> = Grey CI head M20 x 1.5 threads  <b>7</b> = SS head 1/2" NPT threads  <b>8</b> = SS head 3/4" NPT threads  <b>9</b> = SS head M20 x 1.5 threads</p>	<p>Switch Type</p> <p><b>D1</b> = pressure difference switch, fixed differential without scale  <b>D2</b> = pressure difference switch, fixed differential with scale in mbar  <b>D3</b> = pressure difference switch, fixed differential with scale in "wc</p> <p>For adjustable differential please select microswitch A6 in group 6</p>	<p>Range Code (values in mbar)</p> <p><b>M03</b> = (5 - 25)  <b>M05</b> = (10 - 50)  <b>M10</b> = (10 - 100)  <b>M15</b> = (10 - 150)  <b>M25</b> = (20 - 250)  <b>M35</b> = (50 - 350)</p>	<p>Microswitch Type</p> <p><b>A1</b> = General purpose microswitch rated at 15 A; 250 VAC  <b>*A6</b> = elements with adjustable deadband  <b>*A7</b> = 2SPDT switching elements  <b>A8</b> = General purpose microswitch rated at 5 A; 250 VAC; 5 A, 28 VDC  <b>B1</b> = Low differential microswitch rated at 15 A; 250 VAC; 5 A; 28 VDC</p> <p>Please refer to page nos. 120 &amp; 121 for options and specifications of microswitches  <b>* Please contact sales office for additional information</b>  <b>Please check the note under Range Selection Table for Ext applications.</b></p>	<p>Pressure Port Material / Size</p> <p><b>S1</b> = SS316 / 1/4" BSP(F)  <b>S2</b> = SS316 / 1/4" NPT(F)</p> <p>More options available, please contact sales office</p> <p>For additional wetted parts please contact Sales Office</p>	<p>Diaphragm</p> <p><b>*0</b> = Neoprene  <b>*1</b> = PTFE</p> <p><b>*In case of non-metallic diaphragms the ambient temperature range should be (-)20° to 60° C.</b></p>
<b>Enclosure</b>	<b>FR</b>														
Aluminium	7.870														
Grey CI	10.270														
SS	10.420														

eg. A flameproof switch for gas group IIC, with 1/2" NPT cable entry in aluminium housing as 1SPDT pressure switch, having 20 mbar to 250 mbar pressure range, with 15Amp. microswitch, SS316 pressure housing with 1/4" BSP port size & neoprene diaphragm shall be specified by

Group 1	Group 2	Group 3	Group 4	Group 5	Group 6	Group 7	Group 8
□	FR	1	D1	M25	A1	S1	0

Please specify full model number to avoid ambiguity. If only the first two groups are specified while ordering, uncalibrated switches with standard wetted parts and enclosures will be supplied.